



MoreInstructions™

# Deluxe Bottle Filler

## Filler Parts Diagram — WE644 & WE645

- 1) Tank cover
- 2) Tank
- 3) Left Inlet valve (below the tank)
- 4) Right Inlet/Outlet valve (below the tank)
- 5) Level meter
- 6) Suction tube
- 7) Automatically centering, jointed-nozzle
- 8) EC Plate
- 9) Bottle supporting sill, height adjustable
- 10) AISI 304 stainless steel frame with rubber feet

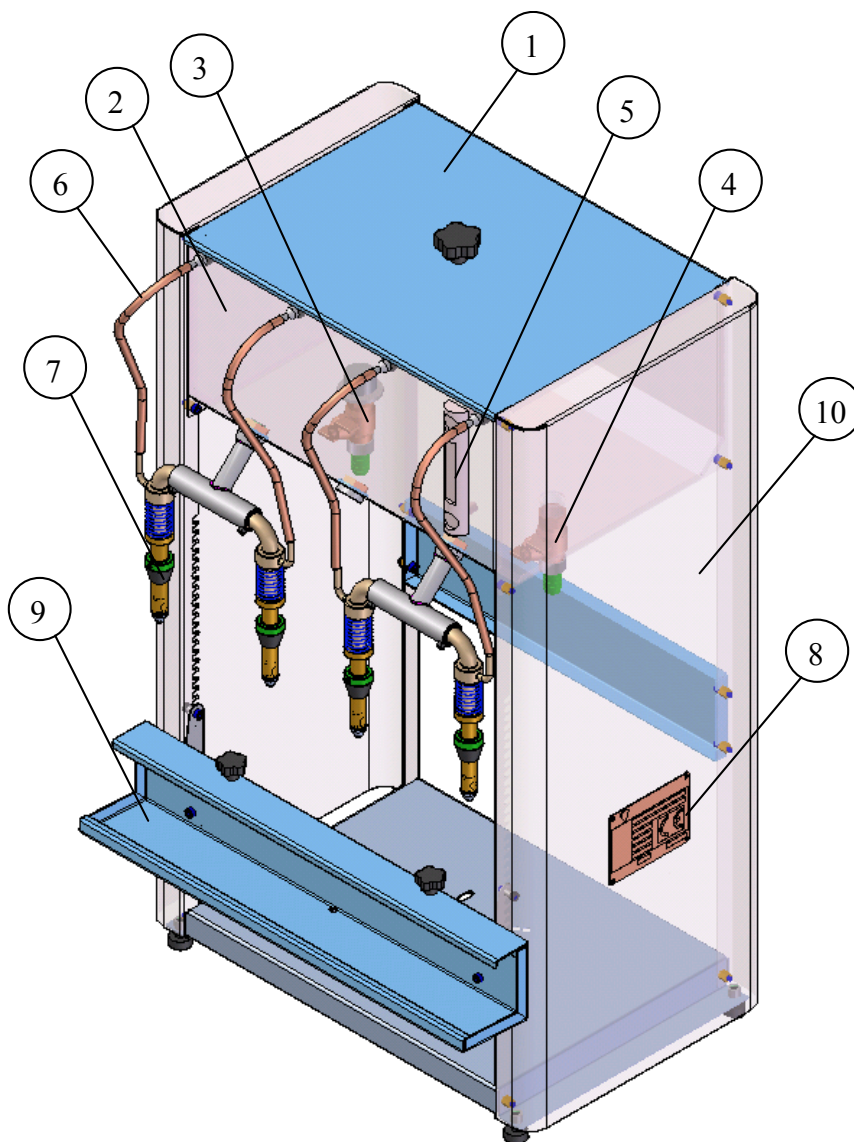



## Clean & Sanitize before Use:

To clean the unit before use we suggest using a non-abrasive, white scotch brite pad (such as our CE27) and a sanitizer. We prefer Star San (CL26) or Saniclean (CL27) sanitizer.

## Standard Operation As Used in Italy:

1. Hook up tubing from your pump (not included) to bottom left input under the holding tank (#3 on drawing page 1.) The built-in float will regulate flow into the tank and put back pressure on the pump to slow down.
2. Adjust bottle holding tray to proper position. When correctly positioned, bottles can be pushed onto spring loaded filling spouts and held firmly in place by tray.
3. Turn on pump and fill holding tank.
4. Insert bottle onto spigot and begin filling.

## MoreWine! Suggested Operation With Pump & Float Switch:

The float valve can put too much back pressure on a pump so we came up with a way to use a small, gentle diaphragm pump (H305) and an electronic float switch (E300) to control the wine level in the holding tank.

1. Hook pump to filler using ½" ID tubing (suggest D1710) to bottom right inlet/outlet fitting on filler (#4 in diagram on the page 1). The valve will need to be converted to accept ½" tubing and your MoreWine! customer service representative can help with this. We do not use the inlet valve, #3 in diagram, for our MoreWine! set up.
2. Bend the flexible float switch over the top of the tank and hold in place with lid. Notching of the lid to perfectly fit the float switch is a suggested practice and can be performed in the MoreWine! metal shop or by a local metal worker.
3. Connect pump to wine source and plug pump into float switch electrical outlet. Power to pump will now be controlled by float switch.
4. Begin filling bottles.

**Suggested Practice** — Flush bottles with inert gas such as Nitrogen or Argon prior to filling.

---

## Cleaning After Use:

To clean the unit we suggest connecting the input of your pump to a clean water source and pumping water through pump and lines and into filler. Allow water to drain through filler heads into bottles.

To drain tank after cleaning, shut valve off on Inlet/Outlet #4. Connect ½" tubing and allow to drain to bucket.

Take apart filling heads, clean and lubricate as needed. See page 3 for directions.

## Dismantling & Cleaning the Nozzles

To substitute the seals, or to carry out a thorough cleaning of the nozzles proceed as follows:

1. Release the locknut and nut (1)
2. Remove the whole nozzle from the “T” connection
3. Holding the spring (3) pressed upwards, unscrew the terminal nose (2)
4. Releasing the spring, the external barrel (4) can be taken away from the internal part (12)

### List of components:

- O-ring seal (5)
- Ring in Teflon (6)
- Seeger ring (7)
- Teflon washer (8)
- Holding ring (9)
- Teflon washer (10)
- O-ring seal (11)

### Cleaning:

Blow compressed air into the terminal holes of the internal part (12)

### Lubrication:

- Lubricate the nozzles monthly.
- Without dismantling the nozzle: insert the nozzle of the lubricator between the coils of the spring and deposit the lubricant on the Seeger ring (7)
- With the nozzle dismantled: deposit the lubricant on the inside of the barrel (4)

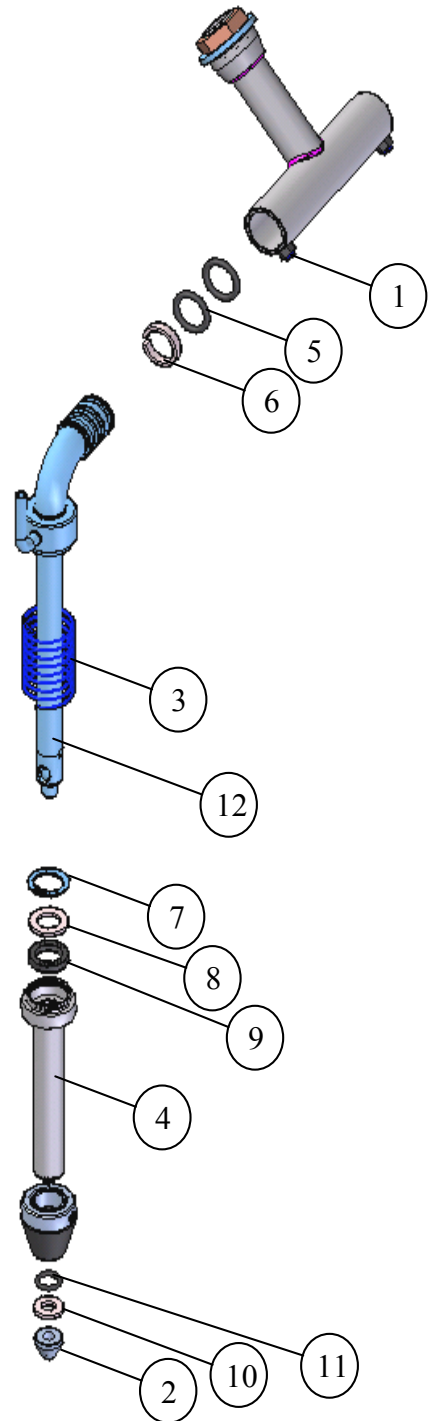

## Regulation of Filling Up Level

To regulate with precision the level of the product in the bottle, operate as follows:

- 1) Release the nut using Allen Wrench (G)
- 2) Move the neck (on which you find the nut) and the holding cone along the post of the nozzle
  - Moving the neck upwards, the level of the product in the bottle reduces
  - Moving the neck downwards, the level of the product in the bottle increases
- 3) Tighten the nut to guarantee that the position reached is maintained.

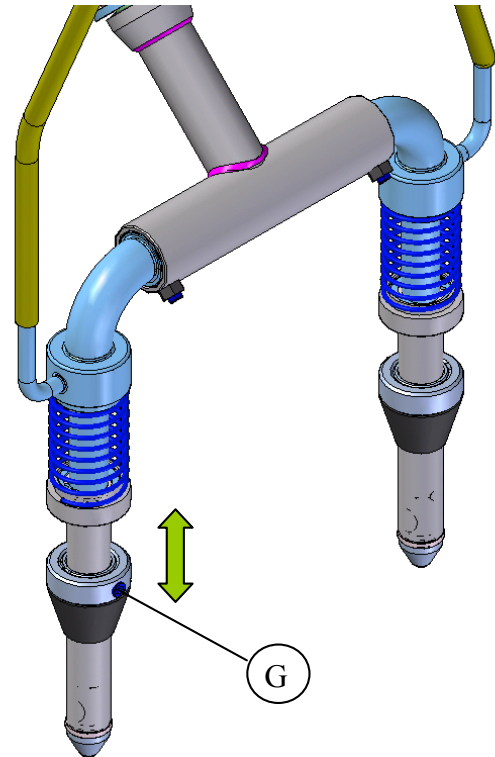

---

## Trouble Shooting Guide

### Product Dripping From Nozzles:

- Worn seals - Substitute the worn seals.

### Nozzles Sliding Badly or Blocked:

- Insufficient lubrication of the nozzle. Insert lubrifilm lubrication between the coils of the spring and deposit the lubricant inside of the nozzle.

### Nozzles Do Not Deliver The Product or Deliver Incorrectly:

Internal connection or connection of air suction is clogged. Dismantle the nozzle and clean by blowing through compressed air (page 3)